



ThermalDESIGNS.

1880 South Flatiron Ct.
Boulder, CO 80301
866-442-3485 fx 303-442-3520
www.thermaldesignsinc.com
sales@thermaldesignsinc.com

Installation Instructions For Four Seasons® Manual Shades

1. Install the Shades into Track

- Shades are labelled in alpha order from left to right (Inside Looking Out).
- Clean track of dirt and debris. Use brush provided or other soft material. Do not use tools that can scratch track surfaces.

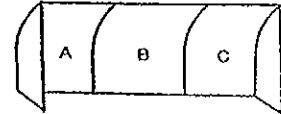

- If installing from a ladder, rest the rolled-up shade on top to hold it while loading into track. The shipping boxes with sides cut off may make a convenient tray for this.



- Place clamp in track 2 feet from ridge to keep shade in place while loading.
- On aluminum models, load shade wheels through existing track cut-outs near the ridge. If cut-outs aren't present, drill them out using a 5/16" drill bit 3 1/2" inches below the ridge. On wood models, remove the access inserts near the ridge first.

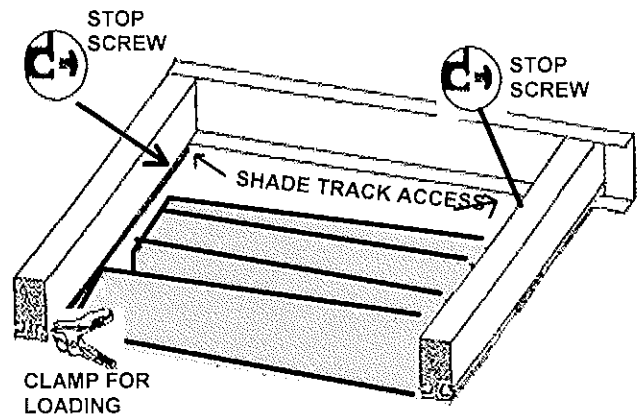

- After loading shade, attach shade stop screws just below each access opening. Pre-drill holes using 1/8" bit provided. Attach stop screws at the same location of each track in every bay.
- Lightly spray silicone into track through the entire length. Always use pure silicon spray, never use WD-40, teflon or other lubricants.

2. Install Headrails

- Attach headrails directly below glazing bars by screwing them into back wall or under ridge. Velstick side, for holding top pleat of shade, will face down. Screw hole placement will indicate mounting point options.

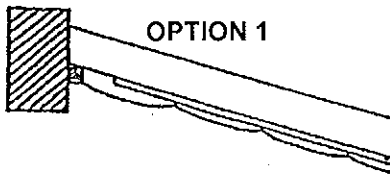

Headrail attached to back wall.

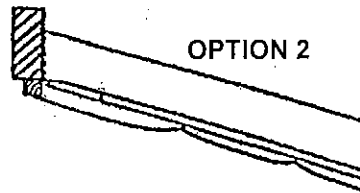

Headrail suspended from ridge. Screw holes go up through velstick on bottom of headrail.

- Headrails with slotted brackets are designed for inside mount between glazing bars. The slotted bracket is adjustable if necessary by loosening the screw attaching it to the headrail. Pre-drill attachment holes into glazing bars with 1/8" bit and use 1/2" tapping screws provided to mount these headrails.

3. Cords

- After attaching headrails, guide shade pull cords through their respective pulleys on headrails, then laterally through cheekblock on end headrail.
- If all shades are to pull together, all pull cords pass around the cheek block on the end headrail.
- If shades are to pull in groups, double or triple cheek blocks are used for each set of cords.

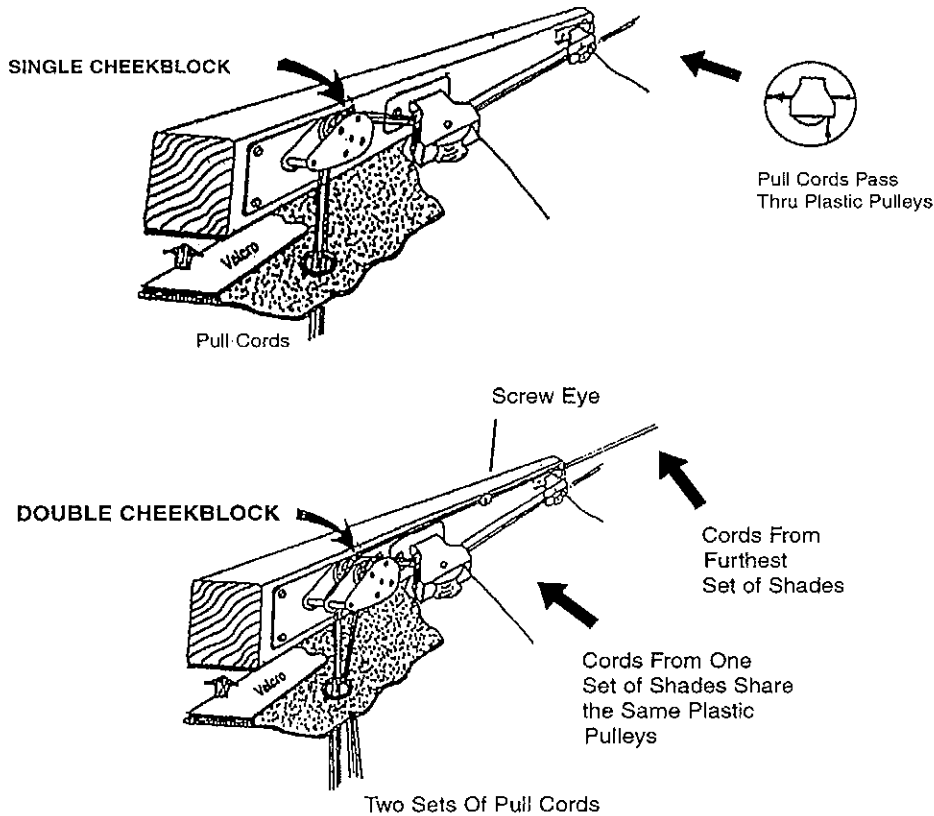

- Run cords from furthest shades through screw eyes to the inside wheel on the cheek block. Without screw eyes, cords can share pulleys enroute to the cheek block.
- Run the cords through the grommet hole in shade underneath cheek block.
- When finished running pull cords, attach top shade pleat to velstick and remove clamp from track. Gently lower shade to its full length. Do not let shade fall as this may damage the lead wheels!

4. FINAL STEPS

- With shades in FULLY EXTENDED, cut excess cord to desired length
- With each set of pull cords, tie a knot 4" below grommet hole in shade
- Slip a tassel onto cord set and tie a knot at the bottom of cords.
- Mount cord cleats at desired wall location about 12" apart so that cords can be neatly wrapped using both cleats.
- Shade pleats should line up across shades. If they do not, minor adjustments to the location of the velstick on the headrails can be made.
- For shade operation, gently raise and lower the shades using smooth action on the pull cords to prevent wheels from bending or breaking. Use pure silicone spray in track annually for lasting, smooth operation.

Wrap cords around both line cleats to keep them neat when shades are pulled up.

